

<i>Manufacturer</i>	GHIDINI BENVENUTO s.r.l.
<i>Product</i>	Ironing table – <b>TORNADO</b>
<i>Year</i>	2007
<i>Certification</i>	

## CONTENTS

1	INTRODUCTION	10	HAZARDOUS USE
2	GENERAL DESCRIPTION	11	OVERALL DIMENSIONS AND DRAWINGS
3	MACHINE IDENTIFICATION	12	MAINTENANCE PROCEDURES
4	TECHNICAL FEATURES	13	DISPOSAL
5	MACHINE COMPONENTS	14	HOW TO ORDER SPARE PARTS
6	MACHINE UNPACKING AND INSTALLATION	15	HANDLING AND TRANSPORT
7	INSTRUCTIONS FOR USE	16	WARRANTY
8	TROUBLESHOOTING AND SOLVING	17	CONFORMITY DECLARATION
9	PRECAUTIONS		

## 1 INTRODUCTION

The present user's and maintenance manual refers to the ironing table "TORNADO".

It is possible to receive the latest release from our Technical Commercial Department or by visiting our website [www.ghidini-gb.it](http://www.ghidini-gb.it). The present user's and maintenance manual contains important information for the operator's health safeguard and safety.

This manual has to be read and kept carefully, in order to be always at the operator's disposal in case of need.

Ghidini s.r.l. cannot be held liable for any damage to things or injury to persons caused by improper use of the machine in contrast with these instructions.

Any possible modifications effected on the components of the machine or its different use without prior written authorization by Ghidini s.r.l., relieve the latter of injury to persons and / or damages to things, voiding any warranty bindings, as well.

## 2 GENERAL DESCRIPTION

The ironing table TORNADO is available in two different versions: TORNADO/A with built-in boiler and automatic water feeding and TORNADO/V without boiler. The TORNADO/A version is completely self-contained and doesn't require any supporting equipment for its operation, but only an external power and compressed air supply, whereas the TORNADO/V needs in addition an external steam supply.

The machine features a broad universal ironing board and (on request) a sleeve shape - both of which are padded, electrically heated and equipped with a vacuum and blowing device -, as well as a garment tray, a control panel to adjust the board temperature and to operate the different working units, a professional steam iron, and an automatic pressure control. Furthermore, it is possible to install on request: a spotting shape, a steam-air gun and a water pump for the automatic feeding into the boiler in case of low pressure inside the waterworks (only for Tornado/A), a supporting iron track complete of lighting, a swivelling iron rest, a water spray gun, a leg divider and a steaming device inside the board. Thanks to the operation controlled by pedal, the machine is very user-friendly and efficient.

## 3 MACHINE IDENTIFICATION

A tag placed on one side of the machine indicates type, serial number, year of construction and the voltage of the machine.

## 4 TECHNICAL FEATURES

	TORNADO / V			TORNADO / A			
Power supply	230V – 1ph / 50 Hz			230V – 1ph / 50 Hz 230-400V – 3ph / 50 Hz			
Power consumption	Iron	Sleeve shape	Table	Boiler	Iron	Sleeve shape	Table
	0,83Kw	0,14-Kw	1-Kw	3,3-3,9-4,8-Kw	0,83-Kw	0,14Kw	1-Kw
Vacuum unit motor	0,6 Hp			0,6 Hp			
Pump motor	Not present			0,5 Hp			
Steam pressure	Not present			2,8 bar			
Steam consumption	Not present			5 ÷ 10 Kg/h			
Sound intensity level	< 70 dB(A)			< 70 dB(A)			
Working temperature	+ 5 ÷ + 80 °C			+ 5 ÷ + 80 °C			
Working humidity	90 % max.			90 % max.			
Storing temperature	- 20 ÷ + 50 °C			- 20 ÷ + 50 °C			
Net dimension	1460 x 520 x 2170 mm			1630 x 520 x 2170 mm.			
Net weight	120 Kg			160 Kg			
Overall dimensions (packaging included)	1740 x 720 x 1280 mm			1890 x 720 x 1280 mm			
Gross weight (packaging included)	180 Kg			220 Kg			

**WARNING:** The machine must not be supplied with different voltages than those indicated on the table.

## 5 MACHINE COMPONENTS

The machine is composed of the following main components:

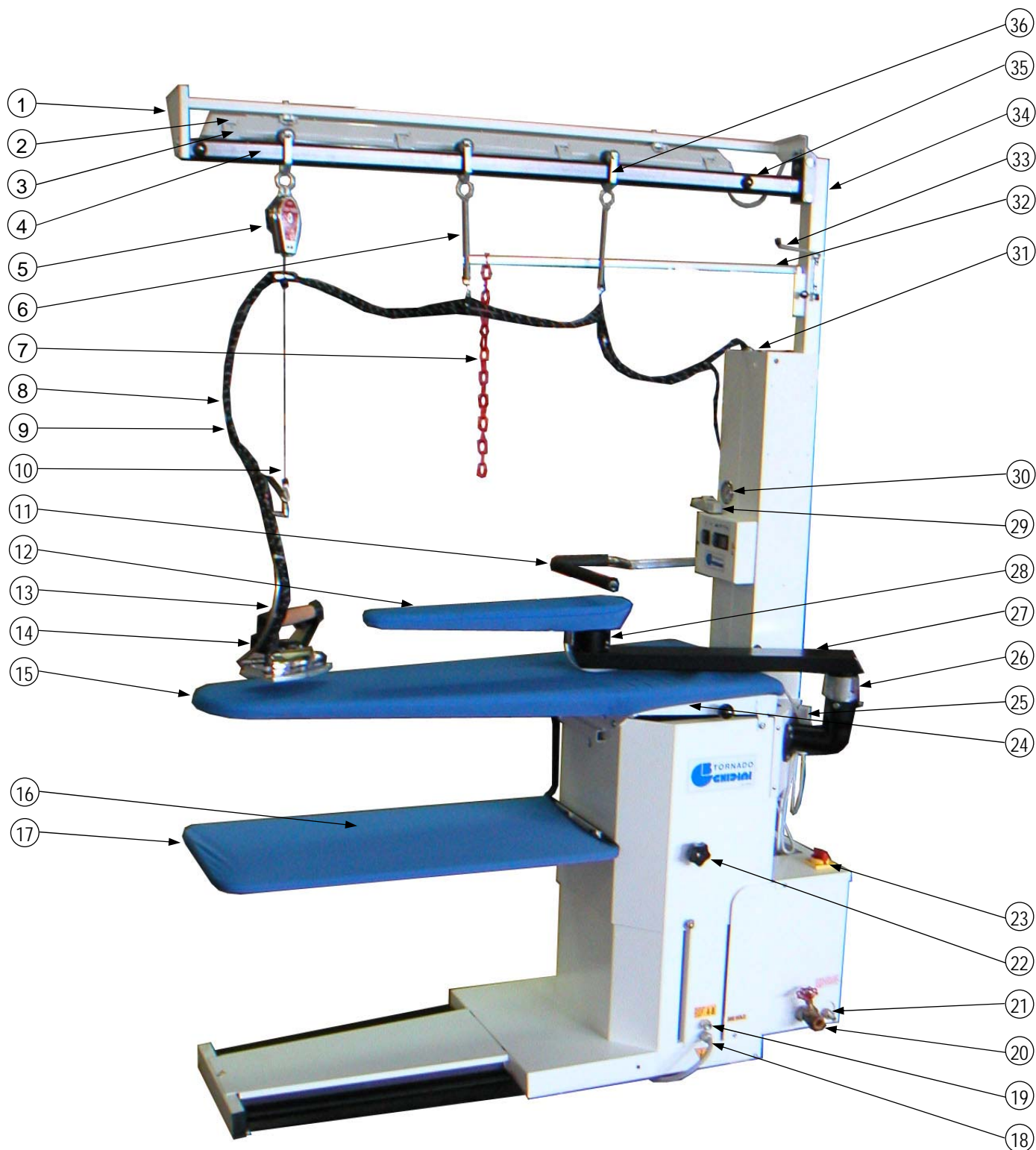



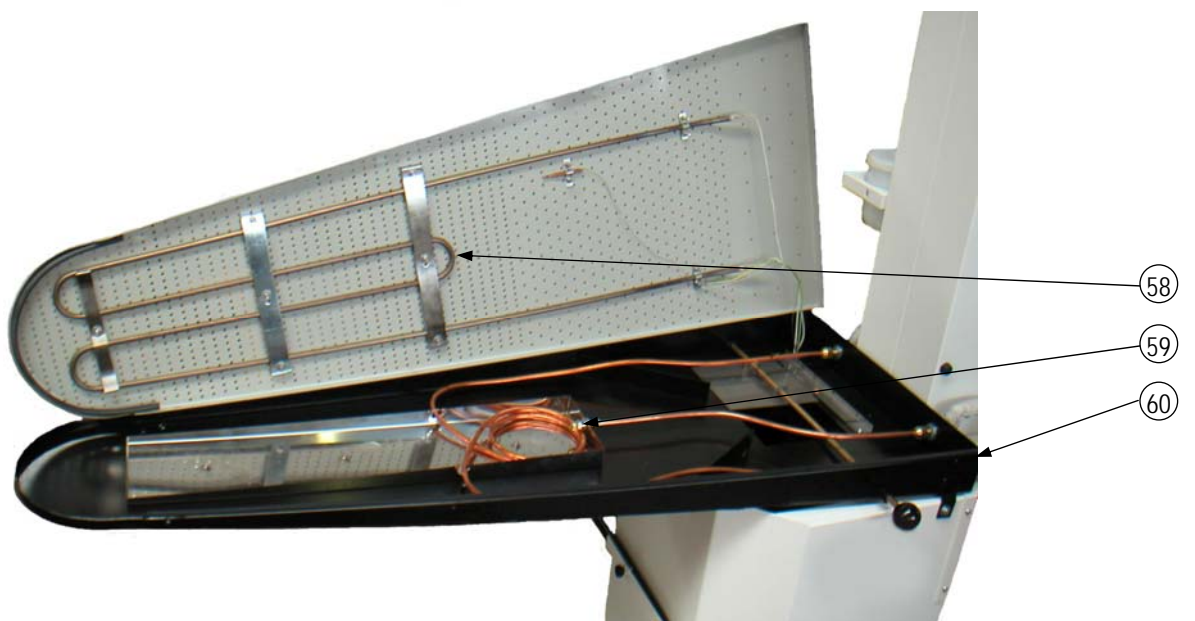
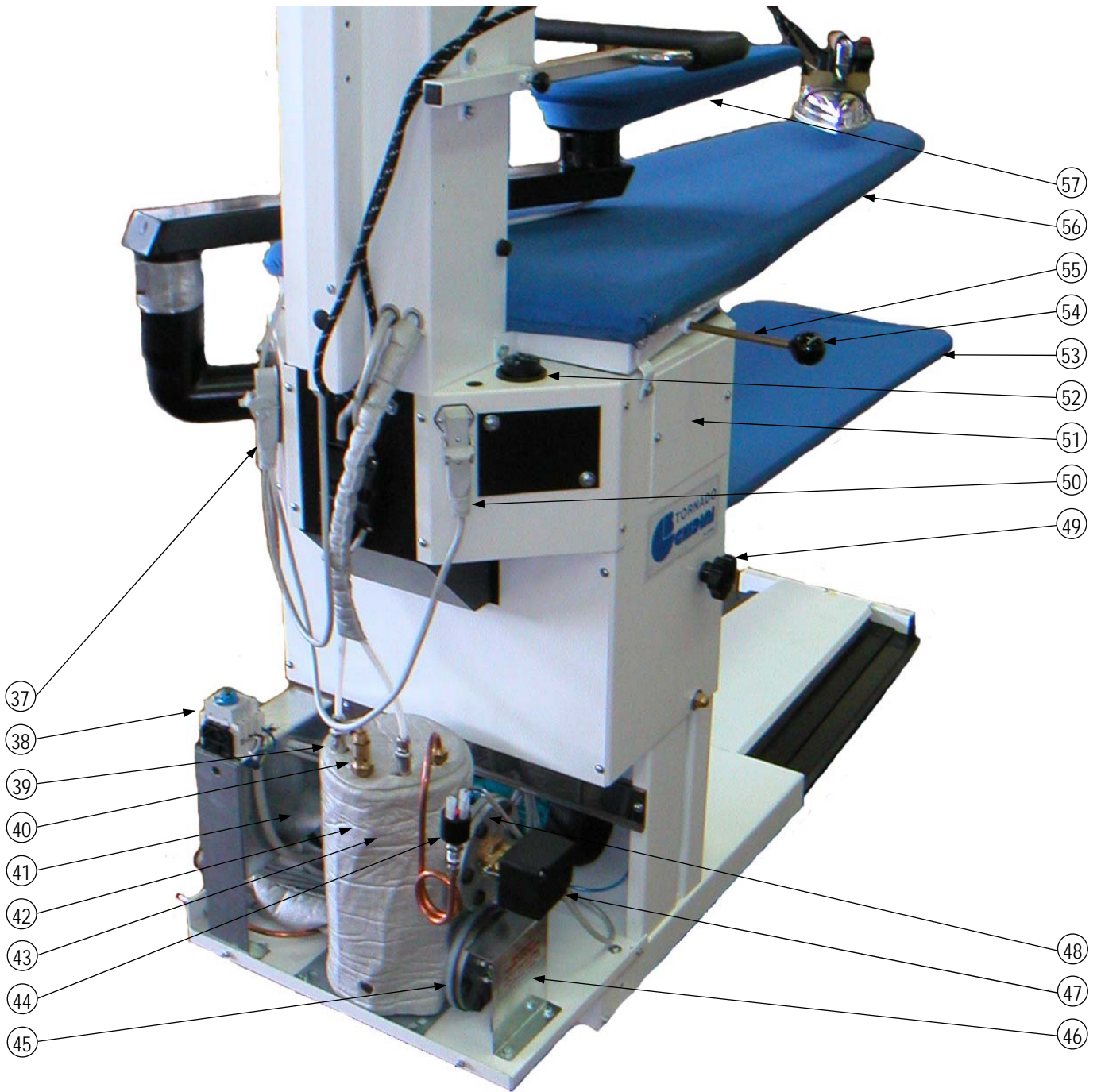

Pos.	ARTICLE	DESCRIPTION	Pos.	ARTICLE	DESCRIPTION
1	174085	Lamp support	31	202048	Condensation separator
2	43C021	Lamp holder	32	173034	Chain support
3	43C009	Lamp	33	174520	Small antenna
4	173304	Supporting track for iron	34	172312	Column for iron support
5	54A001	Balancer	35	22A002	Sliding carrier stop
6	534264	Spring	36	56B006	Complete wheel
7	172310	Chain	37	43H008	Sleeve shape plug
8	07A001	Steam hose	38	43A038	Disconnecting switch
9	Z23C01	Iron cable	39	36L006	Fitting
10	224215	Junction clip	40	38S001	Safety valve
11	172330	Leg divider	41	42B030	Water pump
12	Z27P14	Padding for sleeve shape	42	201024	Boiler 5 lt.
13	174009	Connection for iron support	43	46M017	Boiler lagging
14	Z01L15	Steam iron type "U"	44	45G012	Pressure switch
15	274103	Cloth for Maxi-board with zip fastener	45	Vedi tab.	Boiler heater
	274137	Cloth for Pants board with zip fastener	46	173470	Carter for heater
16	274123	Padding for Maxi-board	47	49A002	Automatic level control
	274132	Padding for Pants-board	48	183270	Level control flange
17	274203	Cloth for garment tray	49	52A010	Height adjustment knob
18	46A021	Power line 4 mt.	50	43H008	Lamp plug
19	36B020	Air intake	51	164426	Inspection panel
20	37B001	Drain cock	52	45C001	Table thermostat 0-90°C
21	36E006	Hose fitting for water intake	53	172308	Garment tray
22	52A010	Height adjustment knob	54	52C003	Ball grip
23	43A043	Handle for main switch	55	172326	Air exclusion rod
24	172311	Maxi-board	56	172138	Perforated plate for Maxi-board
25	43G006	Sleeve shape socket		172129	Perforated plate for Pants board
26	383344	Elbow for supporting arm	57	Z14A01	Sleeve shape
27	Z14H0T	Articulated joint L 600	58	213123	Board heaters with M-shape
28	Z14A01	Sleeve shape	59	35D001	Steam diffuser
29	43G002	Iron socket	60	172334	Steaming Maxi-board
30	35A004	Pressure gauge		172344	Steaming pants board

**EXPLODED DRAWING OF THE SLEEVE SHAPE Ø60 art.: Z14A01**

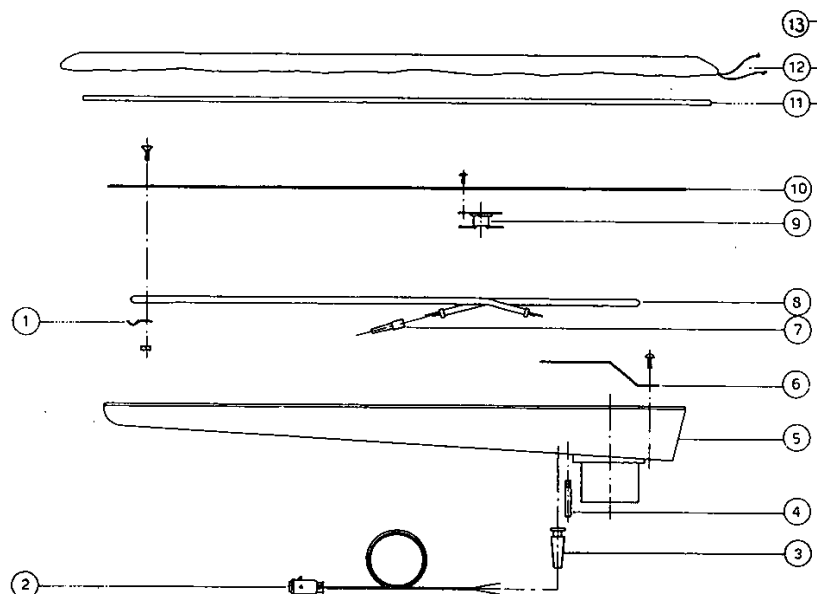

Pos.	ARTICLE	DESCRIPTION	Pos.	ARTICLE	DESCRIPTION
1	174357	U-bolt	8	213113	Heater V230W90
2	43H007	Plug	9	45B001	Thermostat 80°C
3	224216	Cable holder	10	173323	Plate
4	184158	Pin	11	274161	Padding
5	340019	Shape	12	274173	Cloth
6	173343	Deflector	13	Z27P14	Cloth
7	224298	Terminal cover			

## IRON AND LIGHTING RAIL

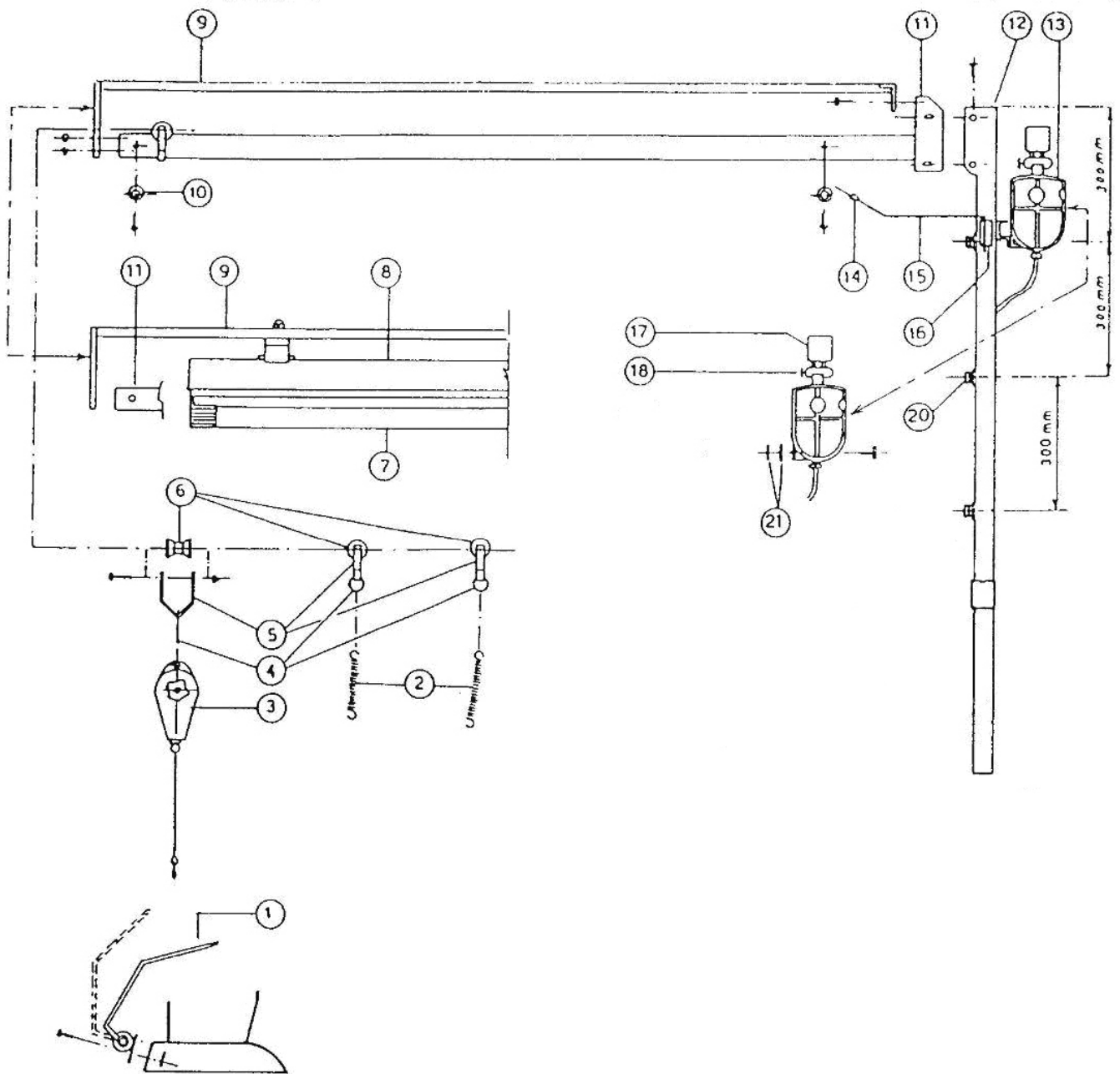

Pos.	ARTICLE	DESCRIPTION	Pos.	ARTICLE	DESCRIPTION
1	174009	Iron support fitting	11	173304	Track L150
2	534264	Spring	12	172312	Upper column
3	43A001	Balancer	13	202052	Condensation separator
4	51X010	Ring	14	22K019	Push rod
5	174022	Bracket	15	174520	Accessory holder
6	56B002	Complete wheel	16	174521	Bracket for accessory holder
7	43C009	Lamp 36W - 230V	17	39H029	Steam solenoid valve coil for iron
8	43C007	Complete upper light fixture	18	39B006	Steam solenoid valve for iron
9	174084	Front lamp support	20	46R005	Cable retainer
10	22A002	Bumper foot	21	244244	Gasket 30x7x3

**HEATERS Ø130**

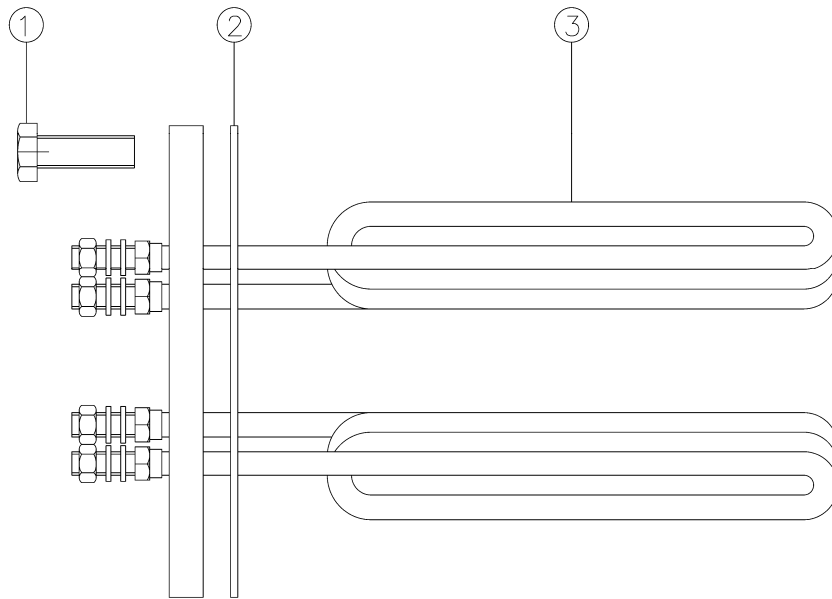

Pos.	ARTICLE	DESCRIPTION	Pos.	ARTICLE	DESCRIPTION
1	50A016	Screw M10x25	3	212061	Boiler heater 3,9 kW
2	244236	Gasket		212060	Boiler heater 3,3 kW
				212063	Boiler heater 4,8 kW



Pos.	ARTICLE	DESCRIPTION	Pos.	ARTICLE	DESCRIPTION
1	Z07P12	Microswitch	4	07A002	Silicone hose for steam supply
2	Z07P13	White switch cover	5	46B011	Electric cable
3	43A040	Red switch cover	6	184537	Shaft with flat fixed nozzle

### VACUUM/BLOWING VALVE

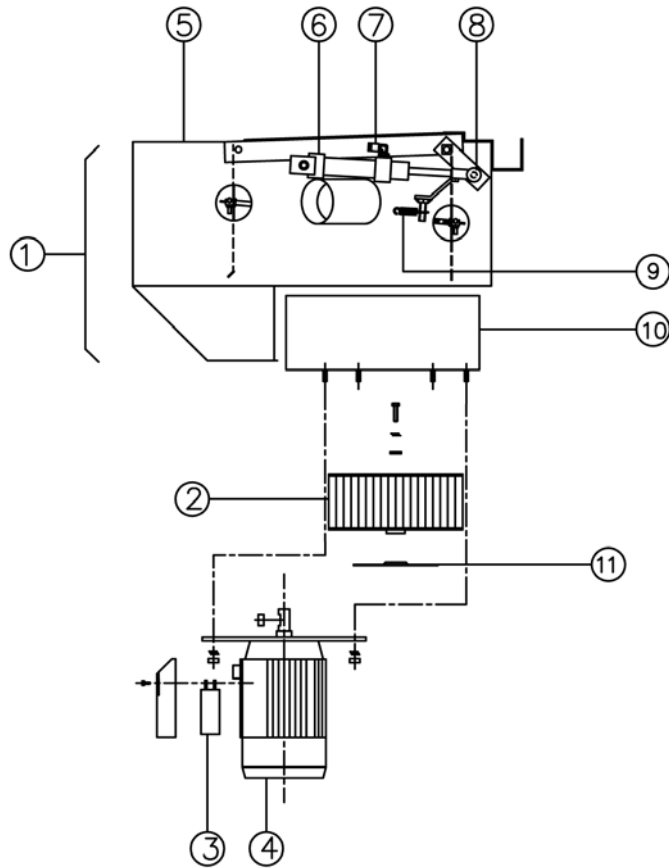

Pos.	ARTICLE	DESCRIPTION	Pos.	ARTICLE	DESCRIPTION
1	381072	Installed valve without motor and fan	6	35C013	Cylinder Ø20 x 50 M8
2	42H003	Fan Ø180 x 90	7	364014	Elbow for air intake 1/8"G x 4
3	42G021	Condenser 10µF	8	60H004	Jointed head M8
4	42A002	Motor 0,6HP V230 Hz50/60	9	534291	Spring
4	42A007	Motor 0,6HP V110 Hz60	10	423356	Scroll
5	171071M	Valve with mounted blades	11	174442	Motor protection flange

### SWIVELLING IRON REST art.: Z27D00

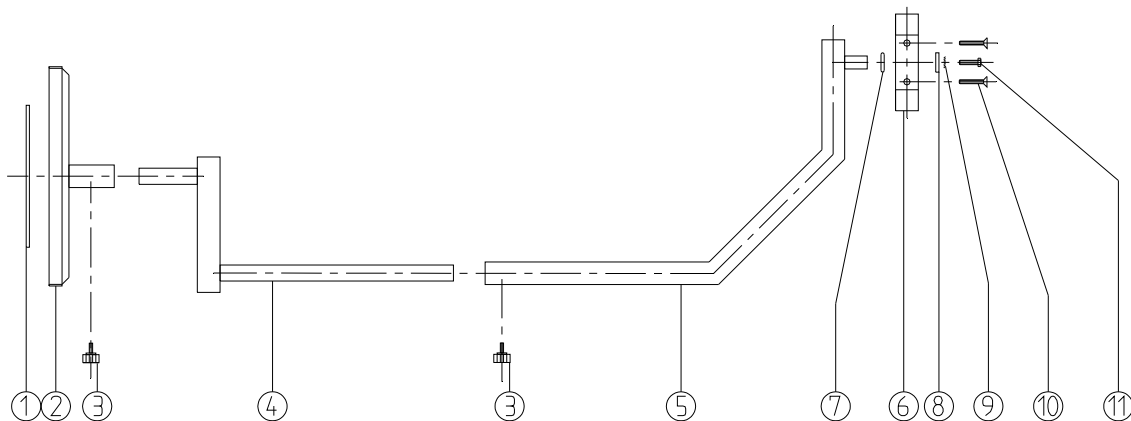

Pos.	ARTICLE	DESCRIPTION	Pos.	ARTICLE	DESCRIPTION
1	25A001	Silicone pad	7	24A012	OR-gasket
2	162156	Iron rest	8	51J005	Washer 8x24
3	52A004	Hand wheel	9	51L003	Indented washer A6
4	172157	Iron rest support	10	50F001	Screw TS M8x45
5	173435	Articulated joint	11	50A007	Screw TE M6x20
6	174495	Pin seat			



### ARM FITTING Ø60

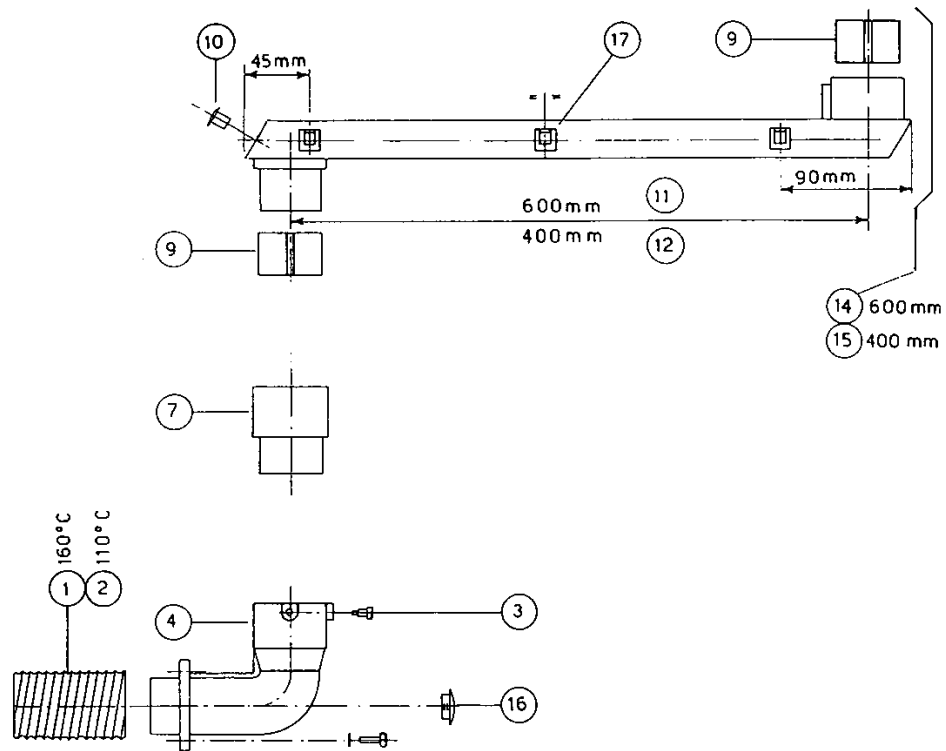

Pos.	ARTICLE	DESCRIPTION	Pos.	ARTICLE	DESCRIPTION
1	06D014	Tube Ø63 160°C	11	Z14H01B	Articulated joint L600
2	06D016	Tube Ø62 110°C	12	Z14H02B	Articulated joint L400
3	184472	Screw	14	Z14H01	Complete articulated joint L600
4	341014	Arm supporting elbow	15	Z14H02	Complete articulated joint L400
7	342110	Valve body	16	22K011	Cap
9	604419	Bushing	17	46R004	Cable retainer
10	22K016	Cap			

### AUTOMATIC LEVEL CONTROL

art.49A002

art. 49A001

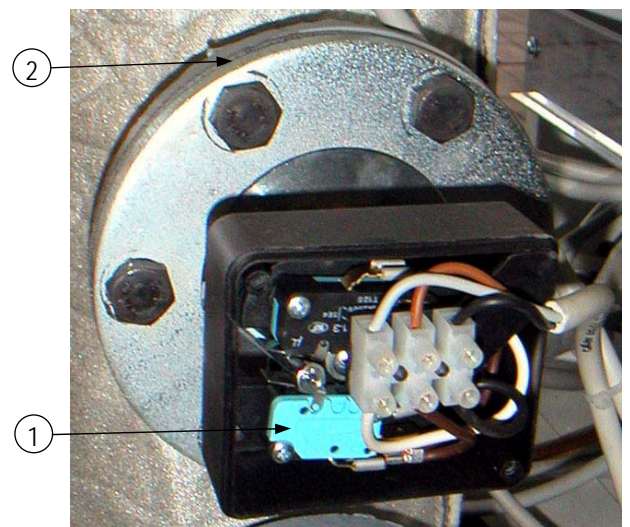
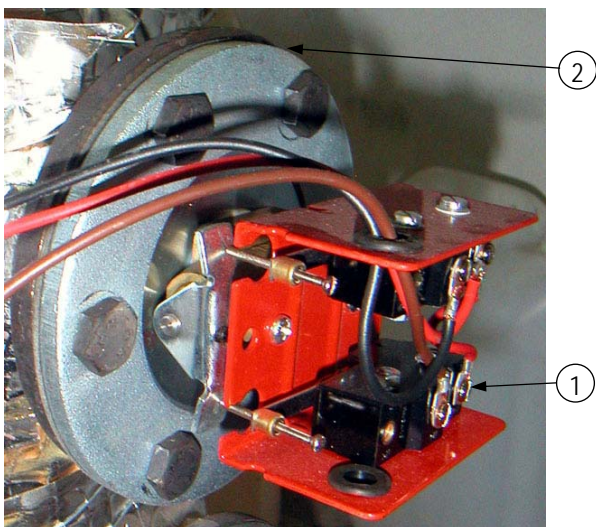

Pos.	ARTICLE	DESCRIPTION	Pos.	ARTICLE	DESCRIPTION
1	43D014	Micro-switch	1	43D013	Micro-switch
2	244236	Flange gasket	2	244236	Flange gasket
3	49G001	Float	3	49G001	Float

## AIR INTAKE AND PNEUMATIC LAYOUT

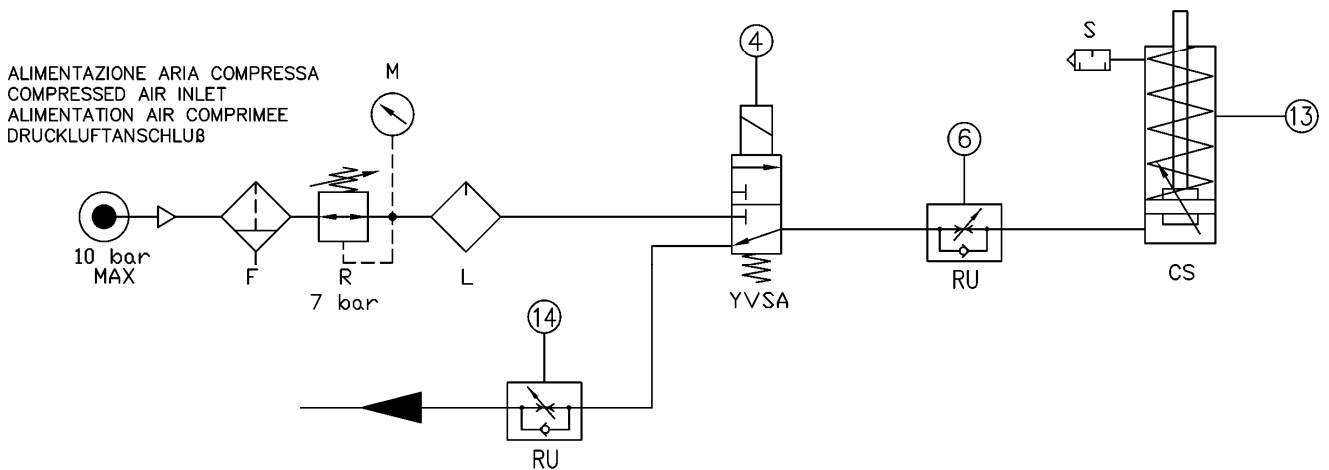
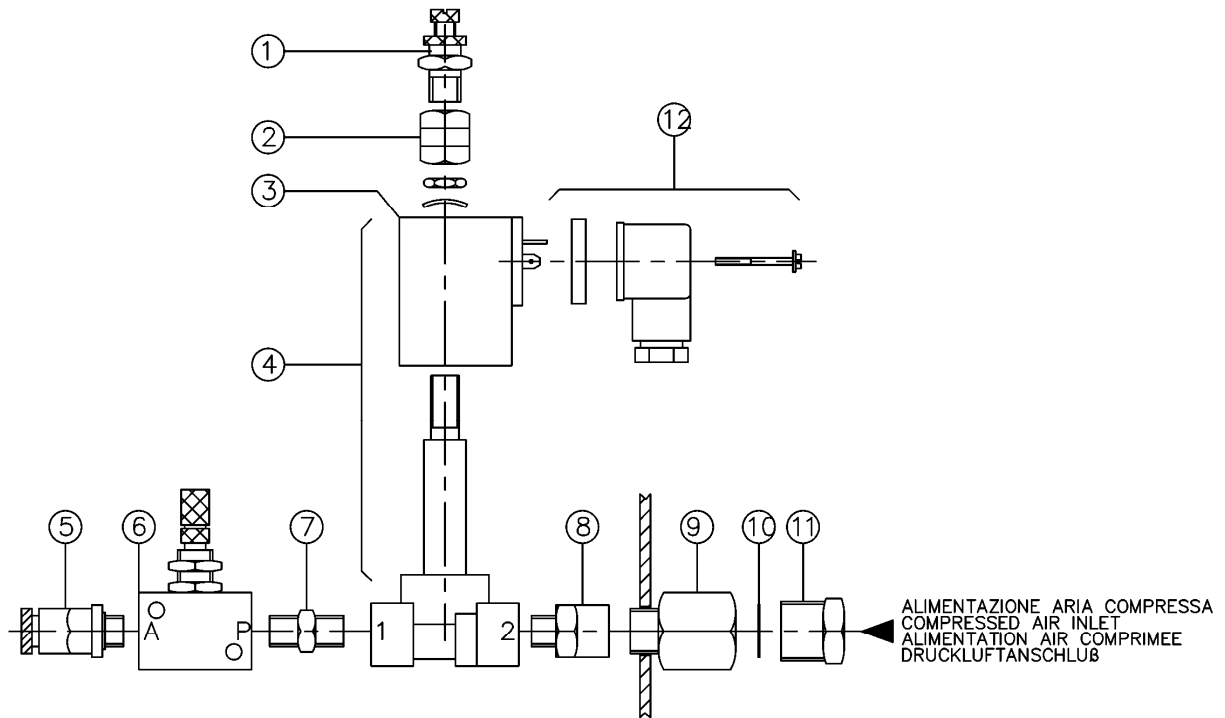

Pos	ARTICLE	DESCRIPTION	Pos	ARTICLE	DESCRIPTION
1	35D006	Silencer 1/8" Gas thread	8	36B021	Adaptor 1/8" – 1/4" MF
2	36D016	Union sleeve 1/8" Gas thread	9	36B023	Adaptor 1/4" – 3/8" MF
3	39H035	Coil 230V-50/60Hz	10	175061	Filter
4	39A003	Complete solenoid valve 230V-50/60Hz	11	36B020	Adaptor 3/8" – 1/4" MF
5	36N001	Air fitting 1/8" Gas thread x 6mm	12	39I001	Connector
6	38A017	One-way regulator 1/8" Gas thread	13	35C013	Cylinder
7	36B007	Nipple 1/8" Gas	14		

**EXPLODED DRAWING STEAM IRON TYPE "U" art.: Z01L15**

TECHNICAL FEATURES	
Power supply	220V 50 Hz
Iron heater	0,830 Kw
Working temperature	+ 5 ÷ + 80 °C
Working humidity	90 % max.
Storing temperature	- 20 ÷ + 50 °C
Net weight	1,8 Kg

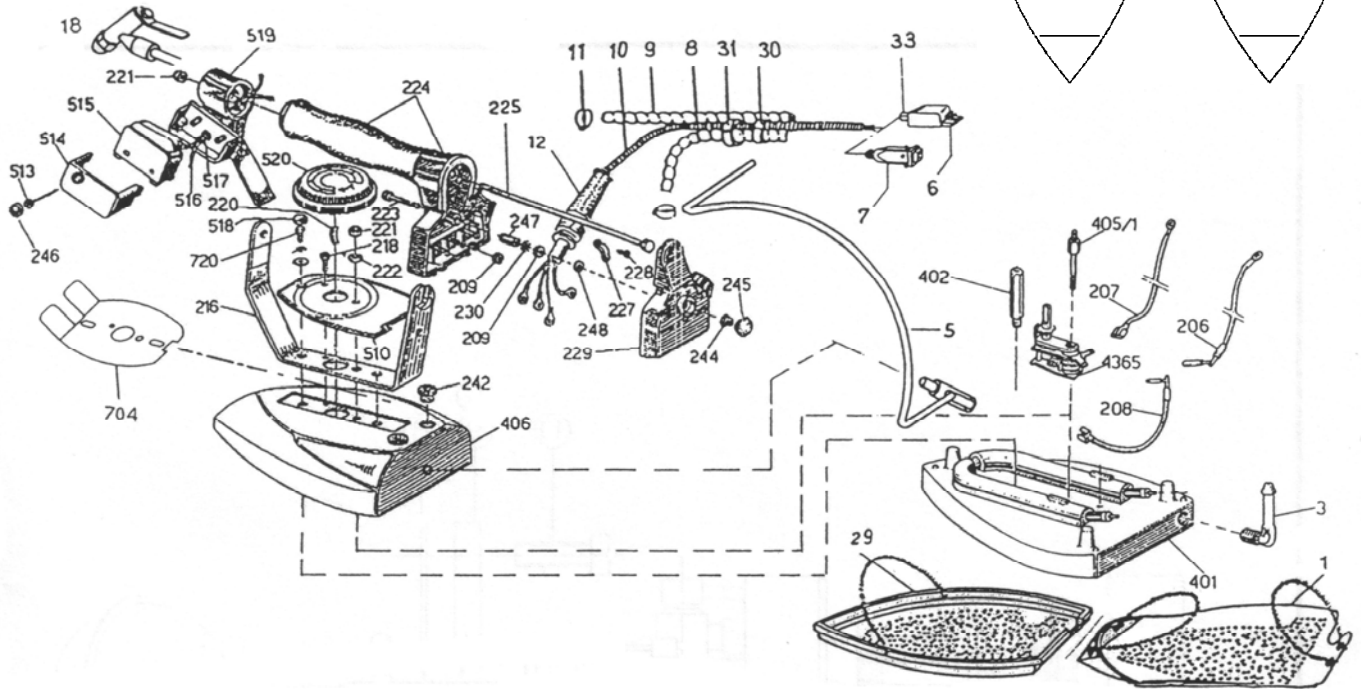
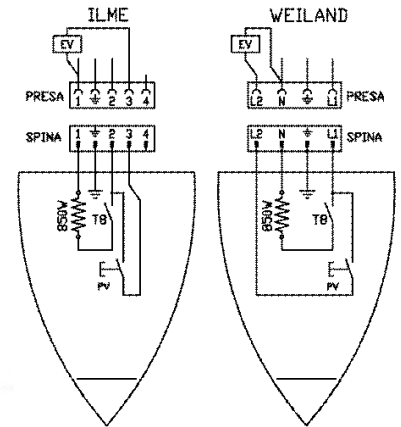
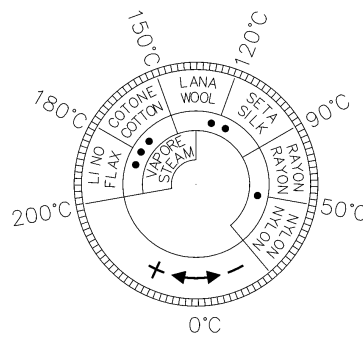

Pos.	ARTICLE	DESCRIPTION	Pos.	ARTICLE	DESCRIPTION
4365	45A005	Thermostat with thermal fuse	224	222056	Handle
720	184453	Fixing screw for body	223	184457	Fixing screw for handle
704	253297	Hand protection plate	222	514057	Fixing nut for body
520	224217	Hand wheel	221	514056	Nut for handle rod
519	173236	Micro-switch support	220	534288	Hand wheel spring
518	22K038	Cap for body screw	218	184455	Fixing screw for body
517	224217	Sheathing	216	172057	Handle support
516	304284	Micro-switch wires	209	514055	Nut for terminal board
515	43D009	Micro-switch complete of wires and sheathing	208	304282	Electrical wiring for thermostat heater
514	43K007	Micro-switch case	207	304281	Electrical wiring for thermostat terminal board
513	184451	Micro-switch screw	206	304280	Electrical wiring for heater terminal board
510	264350	Plate	33	224255	Cable holder for plug
406	253255	Body	31	224260	Wire clamp
405/1	174020	Thermostat column	30	224215	Little spring
402	174019	Body column	29	Z23E01	Stiffened Teflon shoe
401	253254	Plate with heater	18	25A002	Water spray gun
248	184449	Isolating washers	12	224210	Cable holder
247	174018	Earth spacer	11	51X005	Clip
246	22K037	Micro-switch cap	10	Z23C00	Electrical wire
245	22K036	Nut cap	9	07A002	Silicone hose
244	514058	Nut for rear cover	8	07A001	Rubber hose
242	224245	Rubber cap for wire holder	7	43H009	Plug by Ilme
230	184448	Indented washer	6	43H002	Plug by Wieland
229	222133	Rear cover	5	174009	Jointed iron hanger
228	184450	U-bolt screw	3	364297	Cable hose
227	174353	Fixing U-bolt	1	Z23E00	Teflon shoe
225	183255	Handle rod			

## 6 MACHINE UNPACKING AND INSTALLATION

---

**WARNING:** The unit must be installed, opened and repaired by fully qualified technicians only.

### 6.1 UNPACKING

Find the most suitable place where to put the machine, then remove the packaging. Make sure that the machine has not been damaged during the transport and the storage.

The packaging material does not require any special precautions for its disposal, for it is not dangerous or polluting at all. Please refer to the local regulations for its disposal.

### 6.2 MACHINE INSTALLATION

The machine has not to be anchored to the floor, except for the installation on means of transport. For a correct use and operation, as well as for an easy maintenance, leave enough free space around the machine.

Do not place the machine in dangerous and/or explosive/inflammable places.

### 6.3 ELECTRICAL WIRING

The electrical wiring must be carried out as indicated on the drawing. Check that the supply voltage and the frequency correspond to those indicated on the rating plate.

The dimensions of the supply cable must suit the machine absorption and comply with the current regulations.

It is advisable to install a switch with fuses or a circuit breaker on the line. Put the cable in the cable holder, and then tighten. Connect the cable to the feeder line terminals on the control panel, as shown on the drawing of the present manual.

Check the rotation direction of the motors; if not correct, invert two of the three input phases with each other.

**WARNING:** After having carried out all the electrical connections, make sure that the cables are protected against any possible hits and are suitably fixed and isolated.

### 6.4 WATER CONNECTION AND BOILER EXHAUST

**Only for machines with built-in boiler.** Connect the water pipes to the hose fitting Ø12 of the machine. Install an on-off valve and a filter on the water inlet, which has to be closed each evening, in order to avoid any water sucks into the boiler. Connect the gate valve of the boiler exhaust (featuring a G 3/8" threading) to the drainage system.

**Only for machines without built-in boiler (steam connection to a small steam generator).** Connect the steam intake of the machine to the corresponding G 3/8" threaded hole. It is advisable to use a pipe with an internal diameter of at least 8 mm. Install a gate valve on the pipe, in order to exclude the machine from the steam unit. The steam pressure must be of max. 6 bar. Connect a condensation return to the machine through the corresponding hole of Ø 3/8", by using also in this case a pipe with an internal diameter of at least 8 mm. Install on this pipe a gate valve, in order to exclude the machine from the steam unit. Do not bend the pipes at right angles, but at least with a 50 mm radius. Make sure that the pipes have an even incline, especially the one for the condensation return.

Do not use traps, fittings or gate valves with a smaller diameter than the pipe, itself. The piping must not exceed 2.5 meters. The hole of the condensation return has to be at least 150 mm higher than the water level inside the boiler.

**Only for machines without built-in boiler (steam connection to a central steam supply).** Connect a G 3/8" gas thread pipe to the top part of the central unit's steam outlet and place a gate valve next to the machine. Afterwards, connect this pipe to the Ø3/8" Gas steam intake of the machine, making sure to use one with an internal diameter of at least 10 mm. For the condensation return, provide a pipe with exactly the same features of the steam pipe, and install a gate valve close to the machine. Install on the Ø3/8" Gas condensation return fitting a condensation trap with filter, followed by a check valve. For the connection to the gate valve use a pipe with an internal diameter of at least 10 mm. The steam pressure must be of max. 6 bar.

### 6.5 COMPRESSED AIR CONNECTION

The connection to the central compressed air supply must be carried out by means of a G 1/4" Gas threading. Use a pipe having an internal Ø of at least 6 mm. Install a gate valve in order to exclude the machine in case of maintenance and at the end of work.

Make sure that the pressure inside the compressed air system remains between 4 and 8 bar.

## 7 INSTRUCTIONS FOR USE

---

### 7.1 PUTTING INTO OPERATION

- The whole unit can be used, opened and repaired by qualified technicians only.
- It is forbidden to use the machine if flooded by liquids or in particularly aggressive or explosive/inflammable places.
- Do not ignore the dangers for the operator's health and follow the hygienic and safety regulations.
- Make sure that the electrical wiring is carried out correctly according to the current regulations, and that the fuse blocks are closed and complete of fuses.
- Verify if the machine is intact.

### 7.2 HEIGHT ADJUSTMENT OF THE IRONING BOARD

- Make sure that the machine is switched off and that no objects are placed on the ironing board.
- Turn the two knobs placed on the side of the machine anticlockwise.
- Lift or lower the ironing board with both hands from its larger part according to your needs.
- Once reached the desired height, fasten again the knobs by turning them clockwise.

### 7.3 PRELIMINARY STEPS TO BE CARRIED OUT BEFORE EACH STARTING

- Check if the control and safety devices of the boiler (pressure gauge, pressure switch, and safety valve) are intact, and that the automatic level control of the pump (if installed) and the water solenoid valve are not obstructed.
- Make sure that the gate valve of the boiler exhaust is well closed.
- Turn all the switches and the table thermostat off.

### 7.4 USE

- (Machine with boiler) Open the on-off valve of the water and of the compressed air supply.
- (Machine without boiler) Open the steam gate valve, as well as the one for the condensation return and for the compressed air.
- Turn on the main switch of the machine.
- Turn on the boiler switch placed on the machine (the water starts running into the boiler), as well as: the iron switch, the table switch, which is also connected to the heater of the sleeve shape, the board heater, the lighting and the vacuum.
- Adjust the table and the iron thermostat on the required temperature.
- The warning light of the water supply switches on automatically (the water starts running into the boiler).
- Once the water has reached the required level, the relevant warning light switches off automatically, whereas the boiler heater and the relevant warning light turn on.
- After a few minutes the boiler reaches the working pressure of 2.8 bar (check the pressure on the pressure gauge), the relevant warning light switches off automatically.
- The generator is now ready to supply steam.
- Wait until the boards and the steam iron reach the required temperature.
- The machine is now ready for use.
- Push the lower pedal for the vacuum operation on the board, and the upper one for the blowing.
- If the machine features the steaming option, push the external pedal for the operation of the same.
- If required, it is possible to activate the continuous vacuum or blowing option, by turning on the relevant switches.
- At the end of the work, turn off the table by means of the relevant buttons.

### 7.5 USE OF THE SLEEVE SHAPE

- In the working position, with the table point to the left, make sure that the changeover device 'table-arm' is in the 'arm open' position (the ball grip on your right has to be pulled away from the table). Draw the sleeve shape towards the ironing surface into the working position. Push the vacuum or the blowing pedals as described under paragraph 7.6 "Use of the vacuum/blowing table".

### 7.6 USE OF THE VACUUM/BLOWING TABLE

- In the working position, with the table point to the left, make sure that the changeover device table-arm is in the 'table open' position (the ball grip on your right has to be pushed towards the table) and that the sleeve shape (if mounted on the arm) is turned away from the ironing surface.
- Place the garment on the table and push the vacuum pedal (the lower one, closer to the floor). The garment clings to the surface thanks to the sucked air and is ready for the ironing operation.
- If you prefer to iron with the blowing option, push simultaneously both pedals, the lower one (used before for the vacuum option) and the upper one.



- In order to avoid that the garment slips off the table point whenever the blowing option is operated, the ironing should be carried out with the table point to your right. The machine features in fact pedals on both sides, which is also particularly suitable for left-handers.
- By pushing the external mobile pedal, the steaming option on the board is operated (only for versions with steaming option).

#### 7.7 USE OF THE STEAM IRON TYPE "U"

- Turn on the iron switch placed on the machine.
- The temperature of the iron is adjusted by means of the hand-wheel according to the garments to be ironed.
- Wait a few minutes before you start working, until the soleplate has reached the adjusted temperature.
- In case the temperature of the soleplate has to be kept very high, we advise to apply a Teflon® shoe in order to prevent burns of the garment.
- Press the button placed on the handgrip for the steaming.
- Do not use the steam whenever the iron thermostat is below 110°C, in order to avoid any unpleasant and damaging condensation discharges.
- If the piping is longer than 2.5 m, keep the thermostat temperature rather high and do not steam at the beginning directly on the garment to be ironed, as the steam, going through the cold pipe, easily condensates and if the temperature of the soleplate is not able to turn it again into steam, only water will be coming out.
- The steam quantity can be adjusted, by means of the hand-wheel on the solenoid valve: by turning it clockwise it is reduced, by turning it anticlockwise it increases.

**WARNING:** Connect the iron plug to the corresponding machine sockets and do never leave the steam iron switched on, if not used.

#### 7.8 USE OF THE SPOTTING DEVICE "STEAM-AIR GUN"

- Change the vacuum over to the arm.
- Draw the spotting shape into the working position.
- Place the garment to be treated onto the spotting shape, making sure that it lies exactly on the vacuum part.
- Press the steam button of the gun, by turning the condensation-jet first towards a tank until only steam comes out.
- Draw the gun up to 1 cm near to the part to be treated, by pushing at the same time both the vacuum and the steam pedal.
- Once the stain is dissolved, dry the treated part by pushing simultaneously the vacuum pedal and the air-button on the gun.

**WARNING:** Do not use the blowing option during the spotting operation, as every dirt deposits would be blown back, thus damaging the garment, or could be breathed in by the operator.

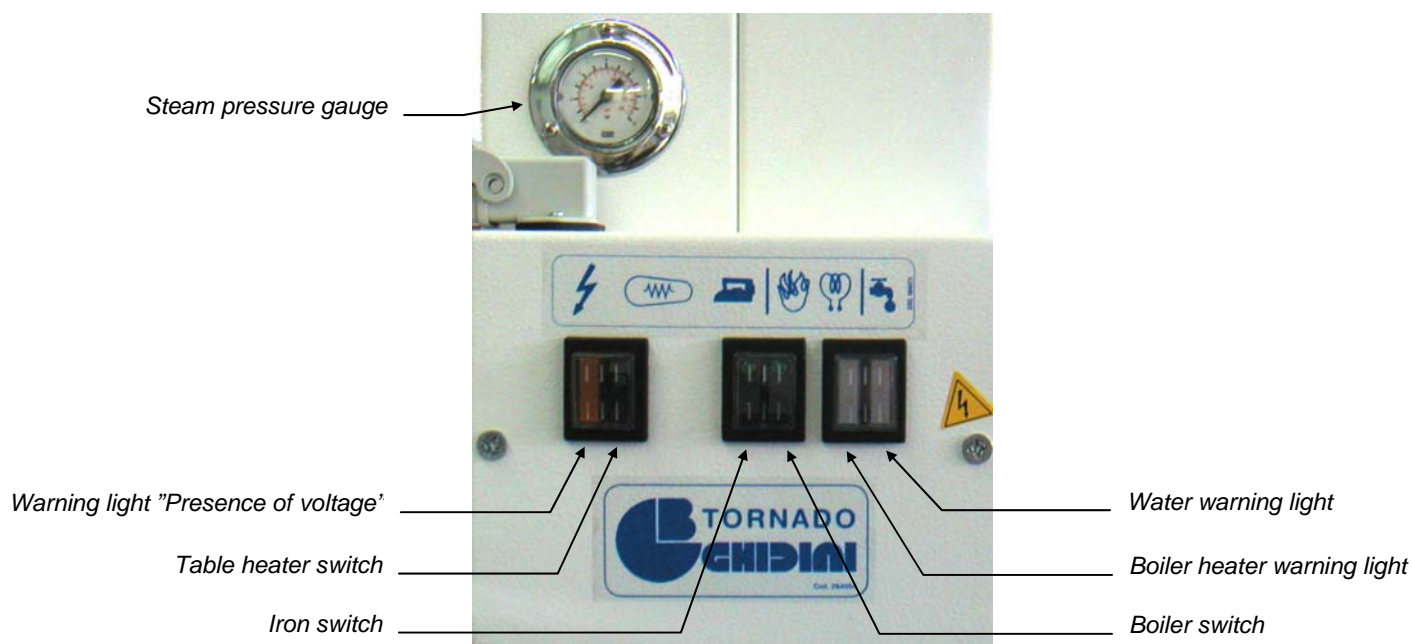

## 8 TROUBLESHOOTING AND SOLVING

The following diagnostic table indicates the main irregularities which can occur, their probable causes and possible solutions

In case of doubts and/or of problems which can't be solved, do not attempt to disassemble parts of the machine for the troubleshooting, but contact our Technical Department or the Ghidini-reseller, instead.

<b>DIAGNOSTIC TABLE (all machines)</b>		
<b>PROBLEMS</b>	<b>POSSIBLE CAUSES</b>	<b>SOLUTIONS</b>
<b>The machine doesn't turn on</b>	Main switch turned off	<i>Make sure that the main switch is turned on, verify the fuses.</i>
	Switch turned off	<i>Turn the switch on</i>
<b>No steaming</b>	Iron or boiler switch turned off.	<i>Turn the switch on</i>
<b>The vacuum option on the boards doesn't work</b>	The vacuum motor doesn't work	<i>Check if the micro-switch installed on the vacuum pedal works properly, if not, it has to be replaced.</i>
		<i>Check the condenser on the single-phase motors, if not working, it has to be replaced.</i>
		<i>Check on the three-phase motors that the remote control-switch and the thermal switches are working properly and correctly adjusted, if not they have to be replaced.</i>
	The micro switch of the pedal is faulty	<i>Replace the micro switch</i>
<b>No vacuum on the boards, even if the vacuum motor is working (only for three-phase motor)</b>	The vacuum motor revolves in the wrong direction.	<i>Exchange the feed phases of the motor.</i>
<b>The blowing option on the board doesn't work</b>	Lack of compressed air	<i>Check if the compressed air intake is open</i>
		<i>Check if the unit has reached the working pressure</i>
<b>The blowing device doesn't work</b>	Mechanical problems	<i>Check the mechanism of the change-over valve, check if all drive bars and blades are working properly</i>
		<i>Check if the cylinder on the change-over valve is worn or not working</i>
		<i>Check if the solenoid valve of the pneumatic device is working properly, the coil could be burnt out.</i>
		<i>Check the pedal stroke and make sure that the micro-switch is pressed down.</i>
<b>The iron doesn't steam</b>	Electric wiring and power supply	<i>Make sure that the iron switch on the control panel of the machine is switched on.</i>
		<i>Make sure that the iron plug is properly connected to the corresponding socket.</i>
<b>The iron supplies little steam</b>	Steaming regulation	<i>Check if the handwheel on the solenoid valve regulating the steam supply is open. Adjust accordingly.</i>
<b>The sleeve shape doesn't steam up</b>	Electric wiring and regulations <b>"Warning: Do not exclude the thermostat, the heater remains turned on. Risk of fire!"</b>	<i>The sleeve shape is connected to the iron, check if it switched on.</i>
		<i>Check if the plug of the sleeve shape is correctly inserted into the corresponding socket and check the wiring, as they could be damaged by the continuous movement of the sleeve shape.</i>
		<i>Check the heater, if burnt out, it has to be replaced. Check if the thermostat is working properly.</i>
<b>The board doesn't steam up</b>	Electric wiring and regulations	<i>The sleeve shape is connected to the iron switch, check if it is turned on.</i>
		<i>Check if the thermostat is faulty or switched to the 0 position. Replace or adjust to the desired temperature.</i>
		<i>Check the heater, if burnt out, it has to be replaced.</i>

<b>DIAGNOSTIC TABLE (machines with boiler)</b>		
<b>PROBLEMS</b>	<b>POSSIBLE CAUSES</b>	<b>SOLUTIONS</b>
<b>The water warning light is turned on and the water pump keeps on running without stopping</b>	No water is streaming into the boiler	<i>Check if the water cock is open.</i>
		<i>Check the presence of pressure inside the water mains.</i>
		<i>Check if the water filter is obstructed.</i>
<b>The water warning light is turned off and there is water in excess inside the boiler</b>	The solenoid valve for the water supply is dirty or faulty	<i>Check or replace the solenoid valve for the water supply</i>
<b>The heater warning light is always switched on and the boiler doesn't reach the working pressure</b>	Leak on the boiler exhaust.	<i>Check if the gate valve of the boiler exhaust is well closed.</i>
	Burnt out heater or covered with scale.	<i>Check the heater condition.</i>
<b>The pump doesn't work</b>	Regulations or electric problems.	<i>Check the regulation of the water level control bulb.</i>
		<i>Check the thermal switch or the condenser (single-phase motor), replace the faulty components.</i>
<b>Steam comes out from the safety valve of the boiler</b>	Pressure switch or safety valve.	<i>Replace the pressure switch.</i>
		<i>Clean or replace the safety valve.</i>

<b>DIAGNOSTIC TABLE (machines without boiler)</b>		
<b>PROBLEMS</b>	<b>POSSIBLE CAUSES</b>	<b>SOLUTIONS</b>
<b>Very wet steam, even after several ironing cycles</b>	Problems on the unit	<i>Check if the exhaust is installed in the correct position and that it is not obstructed.</i>
		<i>Make sure that the check valve is installed in the correct direction.</i>
		<i>Make sure that there are no traps on the pipes of the condensation return</i>
<b>Insufficient steam</b>	Problems on the unit	<i>Make sure that the steam generator is working at a pressure between 4-6 bar.</i>
		<i>The section of the tubes used for the equipment is too small.</i>
		<i>Make sure that there are no obstructions on the equipment (squashed tubes or half-closed gate valves).</i>
<b>Very wet steam along with condensation comes out of the steam iron</b>	Problems on the unit	<i>Check if the filter on the condensation exhaust is dirty.</i>
		<i>The condensation exhaust doesn't work properly.</i>
		<i>The check valve installed after the exhaust remains open</i>
		<i>The check valve on the condensation return doesn't work properly.</i>
		<i>The steam generator doesn't work properly</i>

**AT WARNING:** if the safety valves is released, switch the boiler immediately off and contact a qualified technician. Do not block the exhaust and do not underestimate the problem, as there could be risk of explosion.

## 9 PRECAUTIONS

Read carefully the instructions and the risks related to the use of an ironing table. The operator has to know its working functions and must clearly understand its dangers with the help of the manual.

If the machine features a steam iron, do not leave it switched on for too long and put it always back on the relevant iron rest. The ironing boards and the soleplate of the iron remain hot for some minutes after their switching-off, please pay therefore attention to the risks of burns and do not put objects on the table until its complete cooling-down.

### **Main electrical supply**

Prior to carrying out any inspection or service on the machine, it is necessary to disconnect it from the main electrical supply. Make sure, that nobody can reconnect it during the technical service.

Every installed electrical or electronic equipment must be earthed.

### **Inflammability**

Adopt all the necessary precautions to avoid any direct contact of the machine with hot materials or flames. Put fire extinguishers near the machine for an immediate intervention in event of fire.

**Pressure / Steam**

Prior to any intervention, switch the boiler first off, wait until all the pipes are cooled down and check that there are no residual pressures inside the boiler or in any branch of the hydraulic circuit, as they could cause steam or product spurts, in case of disassembly of fittings or other components.

**Noise**

he machine’s noise level is not very high, as it remains under 70dB (A).

**10 HAZARDOUS USE**

The conformity verification according to the essential safety rules and to the provisions of the machine directive has already been carried out by filling out the specially provided checking lists, included in the technical file.

The checking lists are of two kinds:

- List of dangers (drawn from EN 1050 referring to EN 292)
- Application of the main safety features (Machine Directive– appendix. 1, part 1)

**The dangers described in the following have not been completely removed, but they have been deemed to be acceptable:**

- During the maintenance operation there could be some steam jets at low pressure, (maintenance operation must therefore be carried out by using suitable protection devices)
- The user must provide for a protection against direct and indirect contacts.

**11 OVERALL DIMENSIONS AND DRAWINGS**

1 – Boiler exhaust (1/2” F gas thread)	3 – Power supply
2 – Water intake (pipe coupling 12)	4 – Compressed air intake 4/8 bar (1/4” F gas thread)

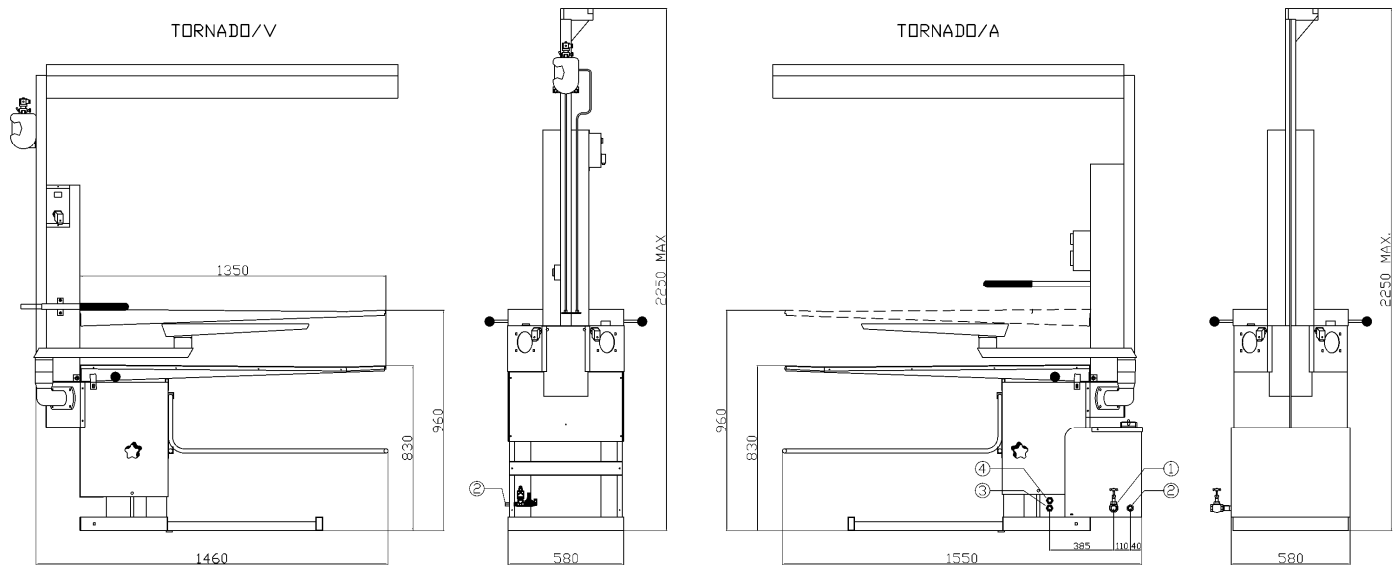

**Types of available boards**

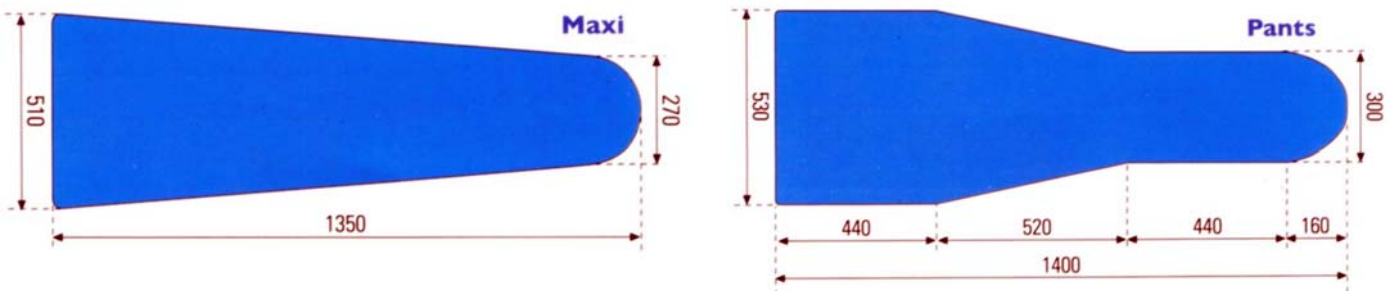

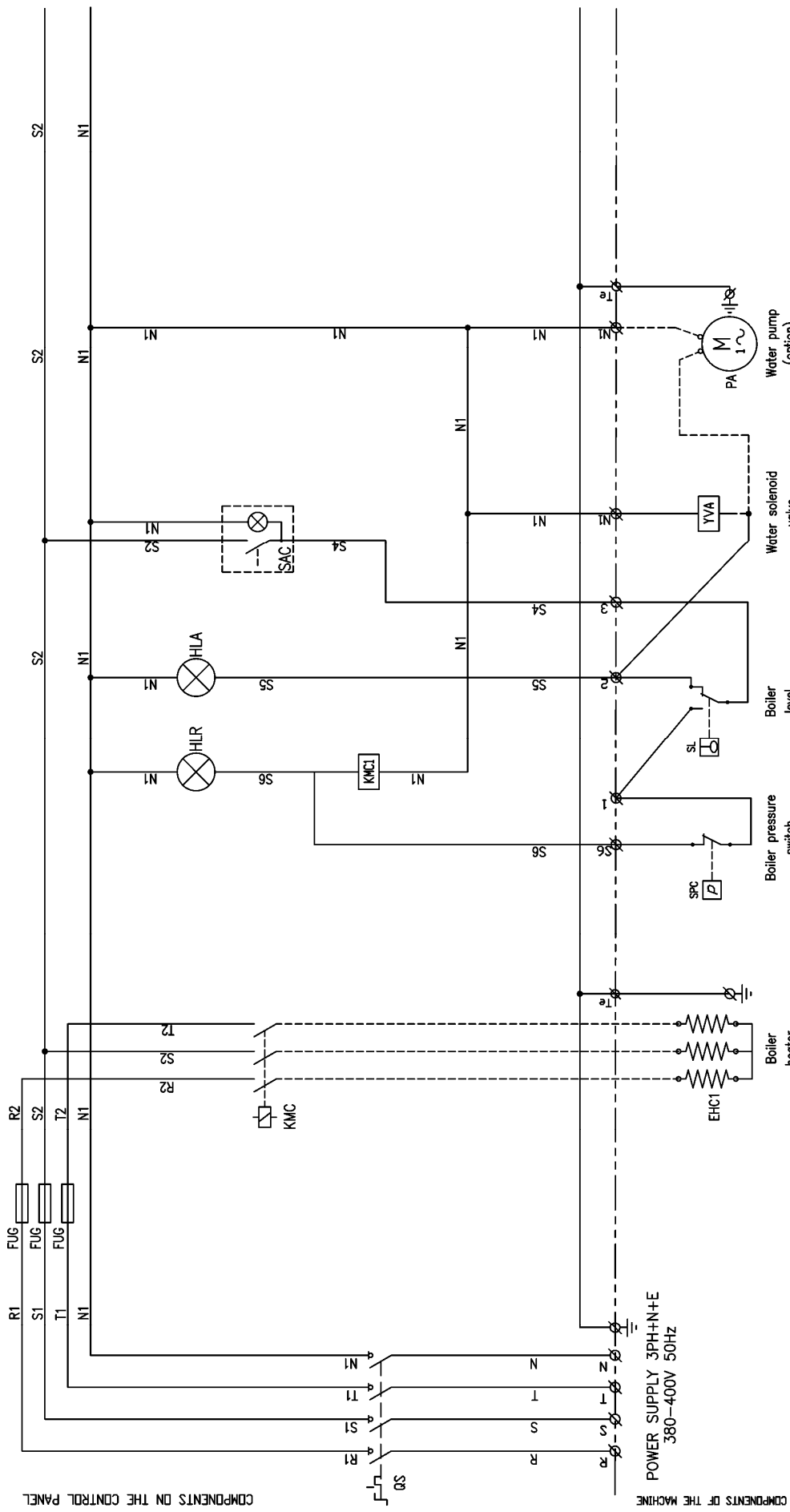

COMPONENTS ON THE CONTROL PANEL

COMPONENTS OF THE MACHINE

Titolo Descriz.		SCHEMA ELETTRICO ELECTRICAL WIRING		Dis. NG Dwg.	
Denominazione Description				Dis. NG	
Tornado A POWER SUPPLY 3PH+N+E				12/06/06	
				A.G.	
				Cod. SETA.2006	
				Appr.	
				Data	
				Firma	
				Segue	
				1/2	

QUESTO DISEGNO VIENE CONSEGNATO ALL'ESPRESSA CONDIZIONE CHE NON VENGA SENZA NS/ CONSENSO NE RIPRODOTTO NE CEDUTO AD ALTRE DITTE

QS: Disconnecting switch art. 43A038  
 FUG: Fuse 20A art. 43F020  
 KMC: Heater contactor art. 44A012  
 EHC1: Boiler heater art. 212061  
 HLR: Heater warning light art. 43A016  
 HLA: Warning light water intake art. 43A016  
 FUG: Fuse holder art. 43F017  
 SAC: Boiler switch art. 43A014  
 SPC: Boiler pressure switch art. 45G012  
 SL: Boiler level control art. 49A001  
 YVA: Water solenoid valve art. 39B042  
 PA: Water pump art. 42B030





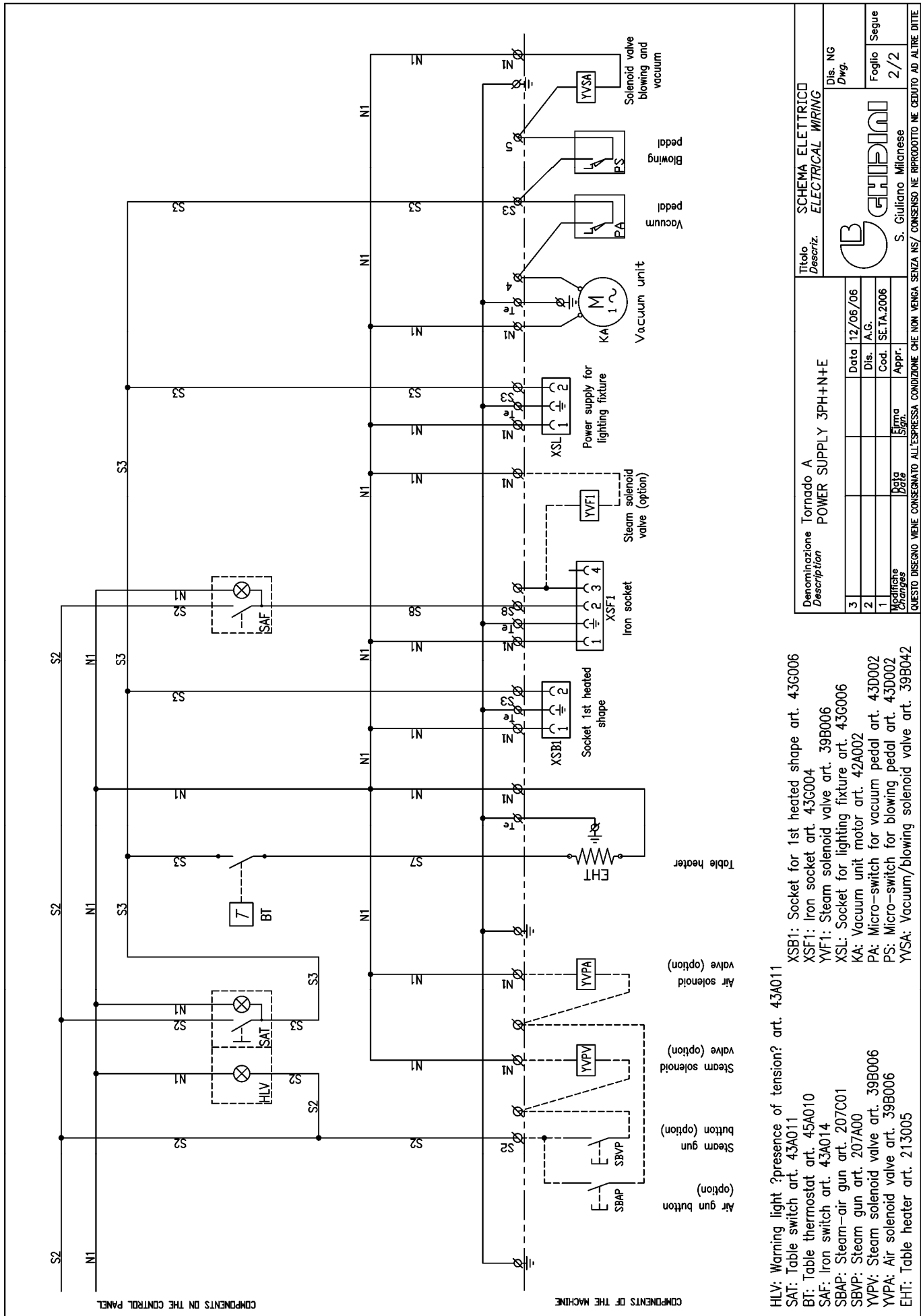

- HLV: Warning light ?presence of tension? art. 43A011  
 SAT: Table switch art. 43A011  
 BT: Table thermostat art. 43G004  
 SAF: Iron switch art. 43A014  
 SBAP: Steam-air gun art. 207C01  
 SBVP: Steam gun art. 207A00  
 YVPV: Steam solenoid valve art. 39B006  
 YVPA: Air solenoid valve art. 39B006  
 EHT: Table heater art. 213005  
 XSB1: Socket for 1st heated shape art. 43G006  
 XSFI: Iron socket art. 43G004  
 YVF1: Steam solenoid valve art. 39B006  
 XSL: Socket for lighting fixture art. 43G006  
 KA: Vacuum unit motor art. 42A002  
 PA: Vacuum unit for vacuum pedal art. 43D002  
 PS: Micro-switch for blowing pedal art. 43D002  
 YVSA: Vacuum/blowing solenoid valve art. 39B042

Denominazione  
Description  
Tornado A  
POWER SUPPLY 3PH+N+E

3	Data	12/06/06
2	Dis. A.G.	
1	Cod. SE.TA.2006	
Firmate Cognomes		Appr.
Data		Segn.

Dis. NG  
Dwg.

Foglio  
Segue  
2/2

**GHIDINI**  
S. Giuliano Milanese

Titolo  
Descriz.  
SCHEMA ELETTRICO  
ELECTRICAL WIRING

COMMENTS ON THE CONTROL PANEL

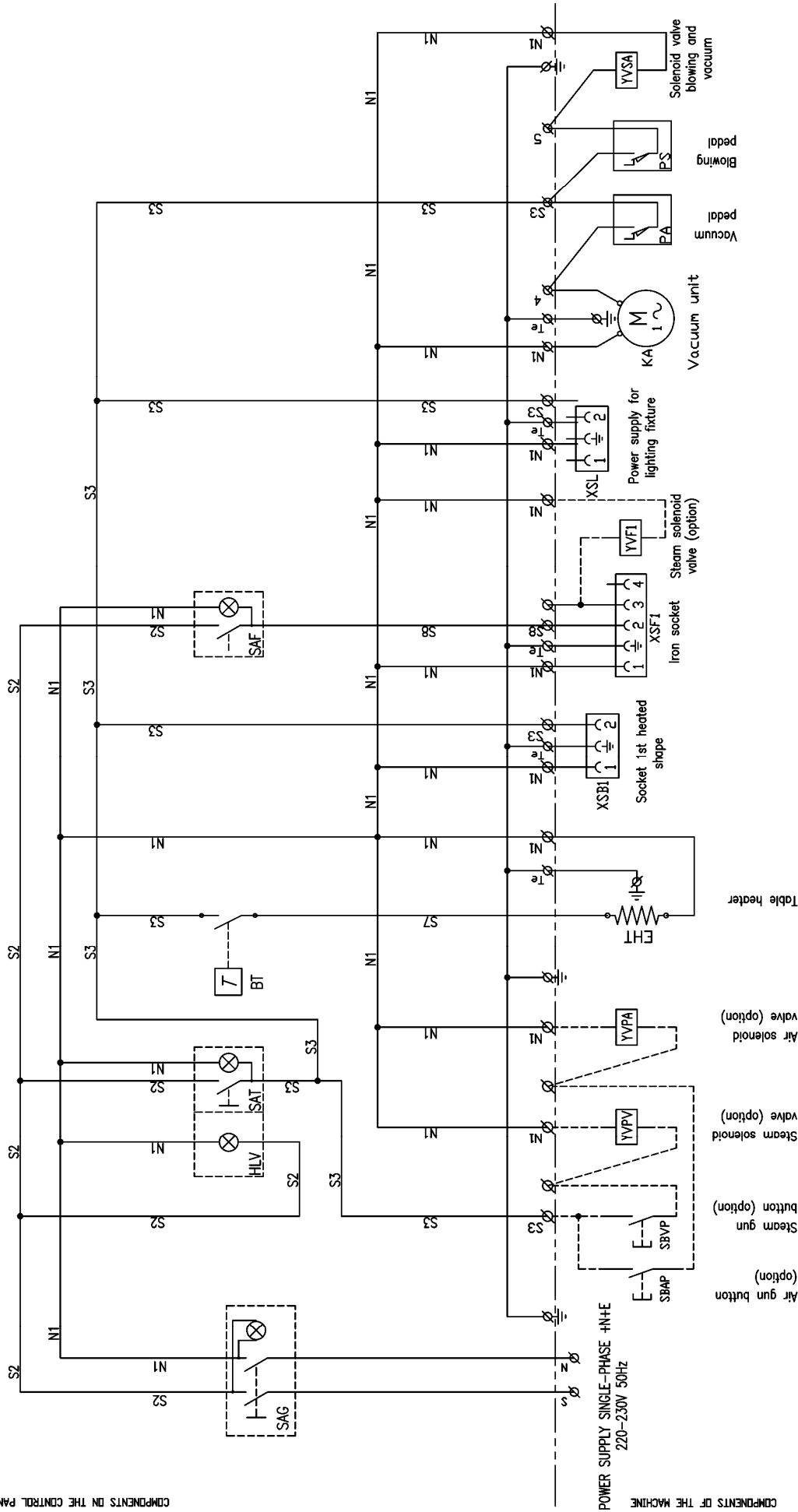

COMPONENTS OF THE MACHINE

- SAG: Main switch art. 43A020
- HLV: Warning light "presence of tension" art. 43A011
- SAT: Table thermostat art. 45A010
- BT: Table thermostat art. 43A014
- SFA: Iron switch art. 207C01
- SBAP: Steam-air gun art. 207A00
- SBVP: Steam gun art. 39B006
- YVPA: Steam solenoid valve art. 39B006
- YVSA: Air solenoid valve art. 39B006
- EHT: Table heater art. 213005
- XSB1: Socket for 1st heated shape art. 43G006
- XSF1: Iron socket art. 43G004
- YV1: Steam solenoid valve art. 39B006
- XSL: Socket for lighting fixture art. 43G006
- KA: Vacuum unit motor art. 42A002
- PA: Vacuum unit for vacuum pedal art. 43D002
- PS: Micro-switch for blowing pedal art. 43D002
- YVSA: Vacuum/blowing solenoid valve art. 39B042

Denominazione  
Description  
Tornado / V (without boiler)  
POWER SUPPLY SINGLE-PHASE +N+E

Titolo  
Descriz.  
SCHEMA ELETTRICO  
ELECTRICAL WIRING

Modificata	Elaborata	Disegnata	Appr.
1	1	1	1
2	2	2	2
3	3	3	3

Data	A.G.	Dis.	NG
12/06/06			
SE.TV.2006			
1/1			

**GHIPINI**  
S. Giuliano Milanese

Foglio  
Segue  
1/1

## 12 MAINTENANCE PROCEDURES

In case of irregularities or malfunctioning, please contact the service technician for the relevant checks.

**Periodically, it is necessary to carry out the following operations:**

OPERATION	WORKING HOURS
Boiler discharge (*)	40
Cleaning of the water filter	1500
Cleaning of the boiler, the heating elements and of the automatic level control	2500
Check of the safety valve, of the pipe fittings and of the connections	1500

(\*): Discharge the boiler once it has reached 1 bar of pressure, in order to remove any limescale or dirt deposits. When the machine is switched off, open slowly the gate valve of the boiler exhaust. We recommend to carry out this operation before you start working and not in the evening at the end of work, as the fresh water streaming into the boiler is rich in oxygen, increasing during the night the corrosion process inside the drum.

This machine does not require special equipment for check and/or maintenance operations. It is however advisable to use suitable tools and personal protections in compliance with the Italian law by decree 626/94, which have to be in good conditions (Presidential Decree 547/55), in order to avoid any damages to persons or machine components.

**Make sure that the power supply is disconnected prior to any maintenance service and that the whole equipment has cooled down.**

## 13 DISPOSAL

During the maintenance on the machine, or in case of its scrapping, please dispose carefully and correctly of any polluting components, according to the local regulations. In case of scrapping, the identification rating plate and any other document have to be destroyed.

## 14 HOW TO ORDER SPARE PARTS

Upon the spare parts request, please quote always:

Machine type, serial number, quantity of the requested spare parts, article number (these data can be read on the rating plate or supplied by the technical information of the machine and by the user's and maintenance manual).

For electrical components with a different voltage and frequency than V 220-380/50Hz (data available on the rating plate of the faulty component), specify the right voltage and frequency after having mentioned the article number.

The technical data, the descriptions and pictures included in this manual are not binding.

The manufacturer reserves the right to make any necessary modification without prior notice or having to up-date the present manual.

## 15 HANDLING AND TRANSPORT

Before its shipment, the machine is carefully packed in a carton box. During the shipment and storing of the machine, pay particular attention to the upside indication on the packaging. Upon receipt, please check that the packing is intact and store the machine in a dry place.

## 16 WARRANTY

All Ghidini products are guaranteed for a maximum period of 12 months from delivery date as far as material and construction defects are concerned.

**The warranty is extended as follows:**

In case of malfunction of the equipment, please contact your Ghidini reseller, specifying the noticed defect, type, serial number and furthermore the operating conditions of the machine. After having received the equipment or component and after an accurate analysis, Ghidini reserve the right, whether to repair or to replace the product. If the machine is still under guarantee, the Ghidini reseller will carry out the service or replacement at Ghidini's charge. In case the returned goods are not defective, Ghidini reserve the right to charge the customer with the met expenses (shipment, etc.). The present warranty will be declared void, if the machine has been damaged due to improper use, negligence, normal wear, chemical corrosion, installation not according to the provided instructions and to the manufacturer's warnings.

Any modification, tampering and alteration on the machine or its components, carried out without prior written authorization by Ghidini, relieve the latter of any responsibility and annuls any warranty obligation. The components subject to normal wear and the perishable ones are not under warranty, as well as everything which has not been previously explicitly indicated, or damages or expenses arising from defects of the same product.

The validity conditions of the guarantee provided by Ghidini are considered implicitly accepted upon purchase of the machine. Any possible changes to or derogations from the present guarantee are only valid prior written authorization by Ghidini.

## 17 CONFORMITY DECLARATION

---

**Manufacturer:**

GHIDINI  
Company

Via Tolstoj, 24 – 20098 S. Giuliano Milanese (MI)  
Address

+39 -02 -98.24.06.00  
Phone number

**Declares that**

**The machine:**

Ironing table – **TORNADO**

- \* has been designed in compliance with the DIRETTIVE DIRECTIVES OF THE EUROPEAN COMMUNITY COUNCIL referring to machines (98/37/EC) and to low voltage (BT 73/23/CEE).
- \* has been designed, as far as enforceable, in compliance with the following harmonized regulations and technical specifications:  
EN 292-1/2, EN 1050, EN 982, EN 11200, EN 60947, EN 894-1/2.

---

Managing director  
Product manager

Roland Fleischmann  
Name

GHIDINI S.R.L.  
Company



Signature

September 2006  
Date



Web site: <http://www.ghidini-gb.it> - E-mail: [sales@ghidini-gb.it](mailto:sales@ghidini-gb.it)